

PRODUCT DESCRIPTION

AEROSOL MASTER® 4000

ROTHER
TECHNOLOGIE

APPLICATION

AEROSOL MASTER® 4000 for lubrication of tools in the chip removal industry. Suitable for machining centres, transfer units, turning lathes and milling machines.

Internal Application (inner lubricant supply):

Aerosol feed from the aerosol unit to the tool via tubing, mono-rotary lead, spindle and tool holder. The tool must have at least one interior cooling channel (see picture 1).

External Application (outer lubricant supply):

Aerosol feed leading from the aerosol unit via tubing through the cooling lubricant channel of the machine tool to a spray nozzle (see picture 2).

- Low-maintenance
- Easy handling
- Easy adaption
- Continuous aerosol activation
- No pressure fluctuations at the tool

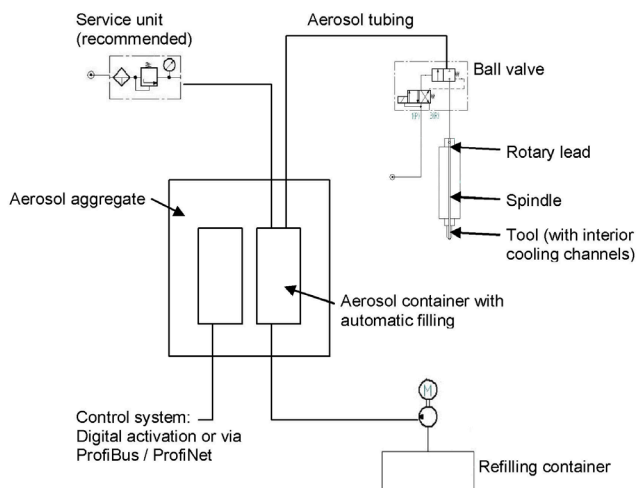

Picture 1: Internal application

MODE OF OPERATION

An oil – aerosol is generated outside of the machine tool. For this purpose compressed air is fed to the aerosol-aggregate. Aerosol is generated in a container with a certain supply of a lubricant medium. The container level is monitored by an integrated control system. Refilling is effected automatically by an external supply assembly and is independent of the machining process (this means continuous machining is possible during the refilling procedure).

Single-channel systems are very much dependent on the pressure difference above the nozzle and from rate of feed. The lower the pressure difference the smaller the quantity of aerosol generated. The higher the rate of feed the higher the applicable oil quantity. This quantity, in turn, is influenced to a great extent by the diameter of the cooling channel and the air supply. Aerosol production and air feed are decoupled as far as possible with the AEROSOL MASTER® 4000. Control of the pressure difference enables continuous aerosol production and constant aerosol flow. Thus no pressure fluctuations at the tool are produced.

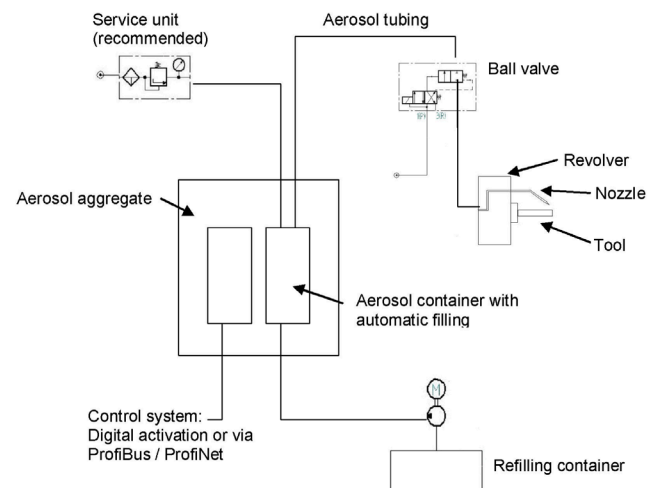

Picture 2: External application

CONDITIONS

In order to achieve a short reaction time, a ball valve is fitted within the aerosol tubing directly in front of the rotary lead or, if possible, near the chip removal. This means the aerosol is available again immediately after a tool change.

Furthermore the machine tool must be equipped with an appropriate suction system as due to process there is no guarantee that all lubricant particles are really “consumed”.

Guidelines of assembly:

The aerosol tubing must ensure a continuous supply of the lubricant where the chips are removed. Therefore following points regarding the assembly of single-channel aerosol tubings must be considered to guarantee an optimum supply and to avoid separation within the tubing:

- Tubings should not have any significant abnormalities in their cross-section nor any obstacles, otherwise the lubricant could condense partially. If cross-section modifications are inevitable, connecting passages should be as smooth as possible (ideal: passage angle $< 15^\circ$).
- Tubings should be straight with no sharp bends as otherwise there is the risk of condensation. If bends in the tubing are unavoidable, they should have a maximum possible radius. All interfaces with the aerosol components should be smooth with no protruding edges.
- Rotary leads and spindles with integrated check valves are to be avoided at all costs. There is no guarantee that these open completely by the low operating pressure of the aerosol system (sufficient lubrication is not provided).
- Feeding in spindles should be effected possibly in axial direction as with radial feeding the lubricant can be “centrifuged” especially at very high revolution rates (separation of the aerosol).

Note:

Only rotary leads may be applied which are designed for dry running. The low lubricant quantities used for aerosol lubrication are not sufficient for adequate lubrication !

CONTROL SYSTEM

The aerosol – aggregate has its own intelligent control system. Activation can be effected in three different ways, two of them are scheduled for the communication with the machine control system. The control system is provided with 27 determined sets of parameters (program nos. 4 – 30). These cover most of the machining processes. Additionally, for three programs (program nos. 1 – 3) the aerosol parameter can be adjusted manually for special applications, as for example in case of very small interior cooling channels.

Digital activation:

The machine control should dispose of 7 digital exits (24 V / DC) and of 5 digital entries (24 V/DC).

Activation via ProfibusDP or ProfiNet:

If the machine tool disposes of a port for ProfibusDP or ProfiNet, activation control can be effected optionally via this bus. A power supply of 24V/DC for the aerosol-aggregate is required.

Activation via manual control unit:

For testing purposes, activation can be effected via a manual control unit (Siemens OP73)



Picture 3: AEROSOL MASTER® 4000

TECHNICAL DATA

 AEROSOL MASTER® 4000	
Dimension (HxWxD)	600mm x 600mm x 210mm
Space (HxWxD)	750mm x 640mm x 830mm
Weight	40 kg
Capacity	2.3 l
Use amount	1.7 l
Power supply	24 VDC
Current consumption	4 A
Inlet pressure	6 bar - 10 bar
Pressure air quality class	5 ISO 8573-1
Pneumatic - Power consumption	1 Nm ³ / min at 6 bar
Air consumption*	10 NI / min - 1300 NI / min
Oil quantity **	0 ml / h - 350 ml / h
Level monitoring	4 - point, 24 VDC
Aerosol container pressure max.	10 bar
Aerosol pressure	0.5 bar - 9 bar

* Depending on the internal cooling channel diameter and inlet pressure

** Depending on the internal cooling channel diameter, inlet pressure and lubricant

 REFILLING CONTAINER (10 liters)	
Dimension (HxWxD)	530mm x 420mm x 250mm
Weight	22 kg
Tank capacity	10 liters (NG12)
Ambient temperature / protection	0 ° C - 40 ° C / IP 55
Flow / pressure	0.375 l / min / 25 bar
Fineness oil - filter	12 µ
Power Supply	400 VAC 3 ~ / N / PE
Fuse	6A
Level monitoring	2 - point, 24 VDC

 BALL VALVE	
Weight	2.2 kg
Medium pressure PN	max. 63 bar
Control pressure	5 bar - 8 bar
Voltage	24 VDC

ROTHER



TECHNOLOGIE

Rother Technologie GmbH & Co. KG
Rübteile 20
D-72574 Bad Urach

Tel: +49 (0) 7125 - 407905
Fax: +49 (0) 7125 - 407990

kontakt@rother-technologie.de
www.rother-technologie.de